

60.8 W SELV constant current LED driver

Product code: 5935

60.8 W 220 – 240 V 50 – 60 Hz

- SELV output protection for safety and flexibility in luminaires
- Low current ripple, complying with IEEE 1789 recommendation
- High efficiency up to 90 %
- Suitable for use in emergency lighting applications
- Current setting via DIP switches
- Ideal solution for Class I and Class II luminaires
- For driving Class III (SELV) luminaires, optional strain relief available for independent use outside of luminaire (LC-SRC)



Functional Description

- Adjustable constant current output: 1050 mA to 1700 mA (default)
- Current setting via DIP switches
- Excellent flicker-free performance per PstLM and SVM characteristics
- Low harmonic distortion to network
- Overload, open & short circuit protection. Short circuit protection with automatic recovery after fault situation is resolved.

Mains Characteristics

Nominal rated voltage range	220 V – 240 V, 50 – 60 Hz
Rated emergency voltage range*	196 V – 254 V, 0 Hz
AC voltage range	198 VAC – 264 VAC
	Withstands max. 320 VAC (max. 1 hour)
	Withstands min. 176 VAC (max. 1 hour)
DC voltage range*	176 VDC – 280 VDC
Mains current at full load	0.28 – 0.31 A
Frequency	50 Hz – 60 Hz
Stand-by power consumption	< 0.5 W
THD at full power	< 5 %
Tested surge protection	1 kV L-N (IEC 61000-4-5) 2 kV L/N-GND (IEC 61000-4-5)
Tested fast transient protection	2 kV (IEC 61000-4-4)

*For emergency use, see details in page 4

Insulation between circuits & driver case

Mains circuit - SELV circuit	Double/reinforced insulation
Mains and output - Driver case	Double/reinforced insulation

Load Output (SELV <60 V)

Output current (I_{out})	1050 mA – 1700 mA (default)
Accuracy	± 5 %
Ripple	< ±3 %* at ≤ 120 Hz
	*] Low frequency
PstLM	< 0.05*
SVM	< 0.01*
	*] At full power, measured with Cree XP-G LED modules.
U_{out} (max) (abnormal)	60 V

I_{LED}	1050 mA	1700 mA
P_{Rated}	46.2 W	59.5 W
U_{LED}^*	22 – 46 V	17 – 35 V
PF (λ) at full load	0.93	0.95
Efficiency (η) at full load	91 %	90 %

*see voltage ranges per selectable current on page 3.

Operating window

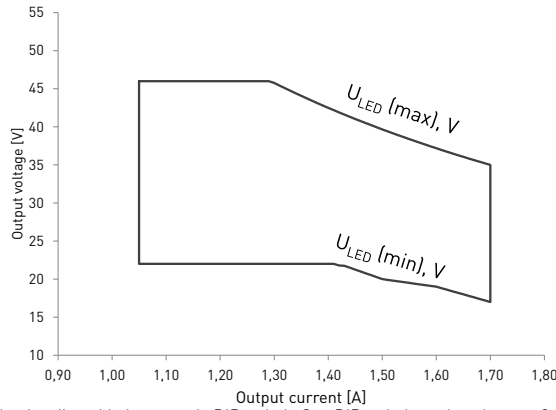

Current value is adjustable in steps via DIP switch. See DIP switch settings in page 3 for details.

Driver performance

Typical efficiency

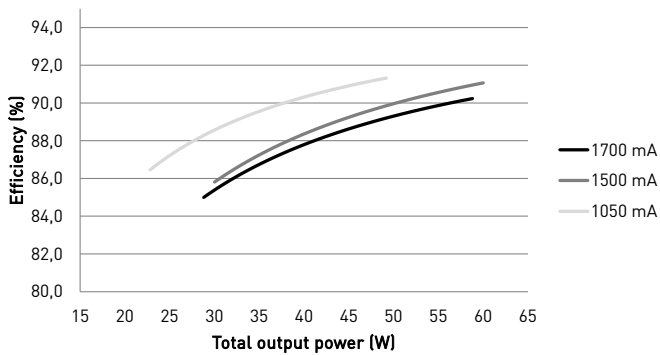

Typical power factor

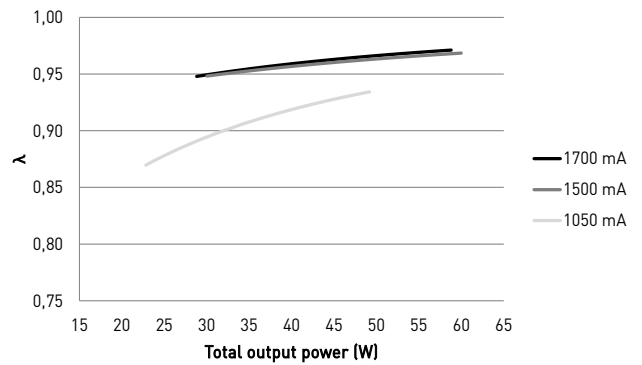

Operating Conditions and Characteristics

Absolute highest allowed t_c point temperature	85 °C
T_c life (50 000 h) temperature	80 °C
Ambient temperature range*	-20 °C .. +45 °C*
Storage temperature range	-40 °C .. +80 °C*
Maximum relative humidity	No condensation
Mains switching cycles	> 100 000 cycles
Life time (90 % survival rate)	50 000 h, at $t_c = 80$ °C 30 000 h, at $t_c = 85$ °C

*) For other than independent use, higher t_a of the controlgear possible as long as highest allowed t_c point temperature is not exceeded

Quantity of drivers per miniature circuit breaker 16 A Type C

Based on inrush current I_{peak}	Typ. peak inrush current I_{peak}	1/2 value time, Δt	Calculated energy, $I_{peak}^2 \Delta t$
39 pcs.	30 A	195 μ s	0.113 A ² s

CONVERSION TABLE FOR OTHER TYPES OF MINIATURE CIRCUIT BREAKER

MCB type	Relative quantity of LED drivers
B 10 A	37 %
B 16 A	60 %
B 20 A	75 %
C 10 A	62 %
C 16 A	100 % (see table above)
C 20 A	125 %

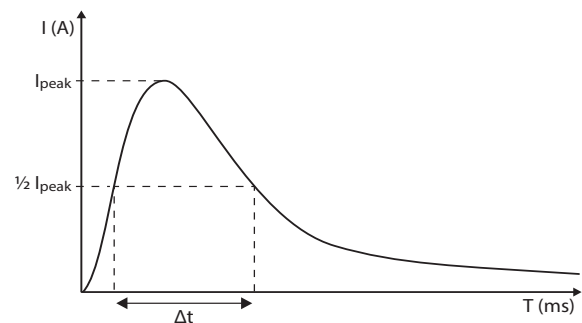

CONTINUOUS CURRENT

Total continuous current of the drivers and installation environment must always be considered and taken into calculations when installing drivers behind miniature circuit breaker. Example calculation of total drivers amount limited by continuous current: $n(I_{cont}) = [16 A (I_{nom,Ta}) / \text{"nominal mains current with full load"}] \times 0.76$. This calculation is an example according to recommended precautions due to multiple adjacent circuit breakers (> 9 MCBs) and installation environment (T_a 30 degrees); variables may vary according to the use case. Both inrush current and continuous current calculations are based on ABB S200 series circuit breakers. More specific information in ABB series S200 circuit breaker documentation.

NOTE! Type C MCB's are strongly recommended to use with LED lighting. Please see more details in "MCB information" document in each driver product page in "downloads & links" section.

Connections and Mechanical Data

Wire size	0.5 mm ² – 1.5 mm ²
Wire type	Solid core and fine-stranded
Wire insulation	According to EN 60598
Maximum driver to LED wire length	1.5 m
Weight	146.4 g
IP rating	IP20

Connections

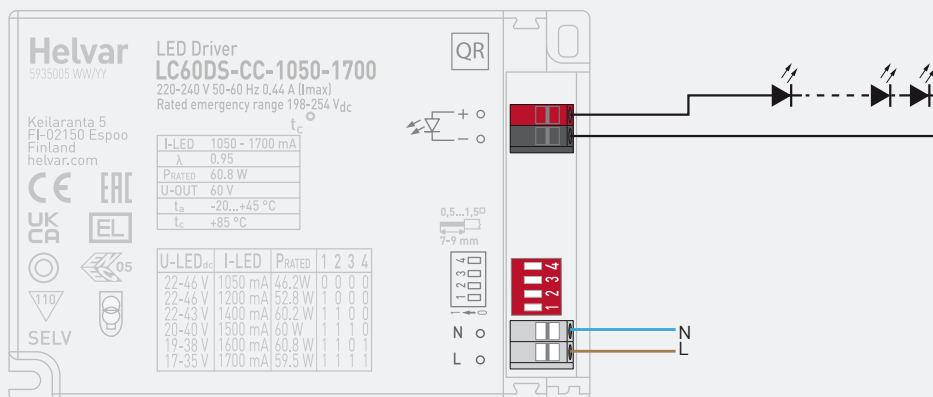

Note:

- Not suitable for load side switching operation

Dimensions (mm)

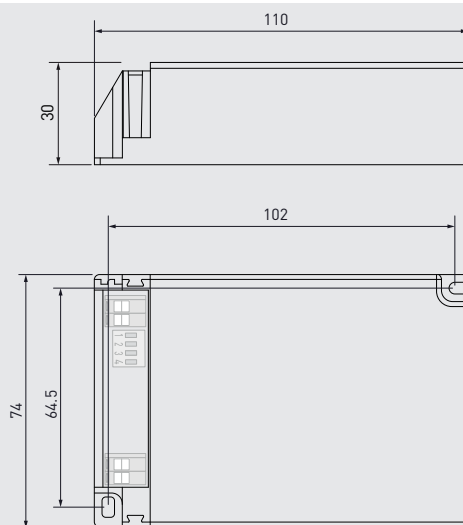

In LC60DS-CC-1050-1700, the current can be set with DIP switches. With each combination of switch setup, a different output current value can be set. The maximum value can be reached with the DIP switches set to "1" (pushed towards to the label, see connections picture above) and minimum with all switches set to "0". The output current values according to the DIP switch settings are presented below.

DIP switch combinations, output currents and voltage ranges (Nominal I_{out} (±5 % tol.))

DIP switch combination	0000	1000	1100	1110	1101	1111
I _{out} (mA)	1050	1200	1400	1500	1600	1700
Voltage range	22 - 46 V	22 - 46 V	22 - 43 V	20 - 40 V	19 - 38 V	17 - 35 V

LC60DS-CC-1050-1700 LED driver is suited for built-in usage in luminaires. With LC-SRC strain relief, independent use is possible too. In order to have safe and reliable LED driver operation, the LED luminaires will need to comply with the relevant standards and regulations (e.g. IEC/EN 60598-1). The LED luminaire shall be designed to adequately protect the LED driver from dust, moisture and pollution. The luminaire manufacturer is responsible for the correct choice and installation of the LED drivers according to the application and product datasheets. Operating conditions of the LED drivers may never exceed the specifications as per the product datasheet.

Installation & operation

Maximum ambient and t_c temperature:

- For built-in components inside luminaires, the t_a ambient temperature range is a guideline given for the optimum operating environment. However, integrator must always ensure proper thermal management (i.e. mounting base of the driver, air flow etc.) so that the t_c point temperature does not exceed the t_c maximum limit in any circumstance.
- Reliable operation and lifetime is only guaranteed if the maximum t_c point temperature is not exceeded under the conditions of use.

Current setting via DIP switch

LC60DS-CC-1050-1700 LED driver features a constant current output adjustable via DIP switch combinations

- For the combination/current values, refer to the table on page 3.

Emergency use

- The product can be continuously operated only with AC, the DC is reserved only for emergency usage.

Miniature Circuit Breakers (MCB)

- Type-C MCB's with trip characteristics in according to EN 60898 are recommended.
- Please see more details in "MCB information" document in each driver product page in "downloads & links" section.

Installation site

- The general preferred installation position of LED drivers for independent use is to have the top cover facing upwards.

Lamp failure functionality

No load

When open load is detected, driver limits output voltage according to $U_{out} (max)$ (abnormal).

Overload

Driver can withstand overload, however reliable operation of the driver is only guaranteed in specified operational voltage range.

The LED load will start to blink when overload occurs.

Short circuit

Driver can withstand output short circuit and after resolving the fault, driver recovers normal operation automatically.

Conformity & standards

General and safety requirements	EN 61347-1
Particular safety requirements for DC or AC supplied electronic control gear for LED modules	EN 61347-2-13
Additional safety requirements for AC or DC supplied electronic controlgear for emergency lighting	EN 61347-2-13, Annex J
Mains current harmonics	EN 61000-3-2
Limits for voltage fluctuations and flicker	EN 61000-3-3
Radio frequency interference	EN 55015
Immunity standard	EN 61547
Performance requirements	EN 62384
Recommended Practices for Modulating Current in High-Brightness LEDs for Mitigating Health Risks to Viewers	IEE1789 - 2015
Compliant with relevant EU directives	
RoHS / REACH compliant	
ENEC and CE / UKCA marked	

Label symbols



Safety isolating control gear with short circuit protection (SELV control gear).



Double insulated control gear suitable for built-in use.



Thermally controlled control gear, incorporating means of protection against overheating to prevent the case temperature under any conditions of use from exceeding 110 °C.



AC/DC supplied electronic control gear for emergency lighting purposes intended for connection to a centralized emergency power supply.