

freedom in lighting

1. Lock the bottom part to the driver so that it clicks into place.

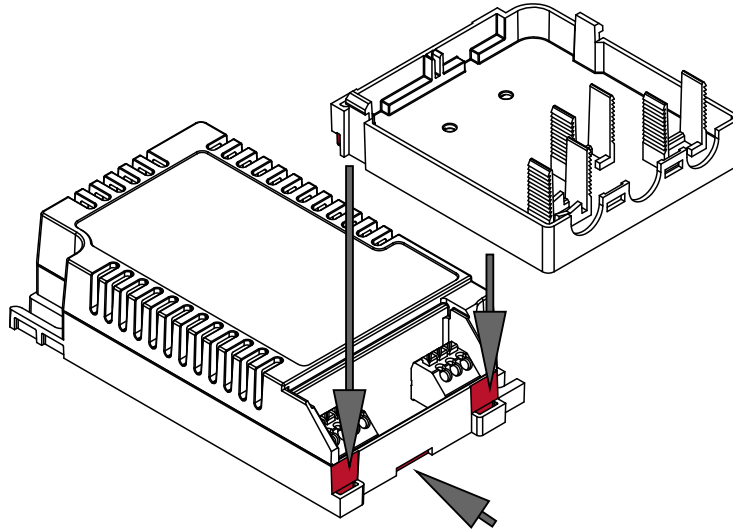

2. Connect wires into correct terminals according to driver datasheet instructions.

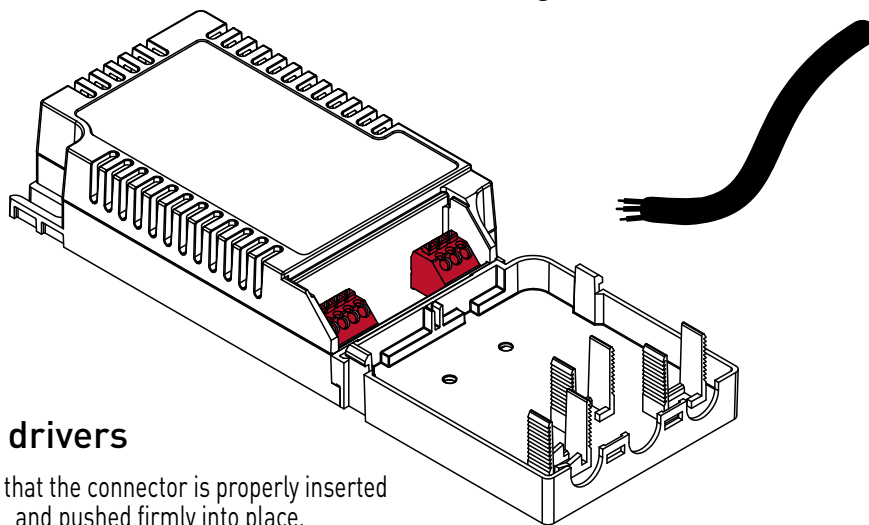

NOTE for Active+ drivers

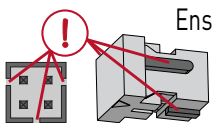

Ensure that the connector is properly inserted and pushed firmly into place.

Avoid tension to the connector, no pushing or pulling force.

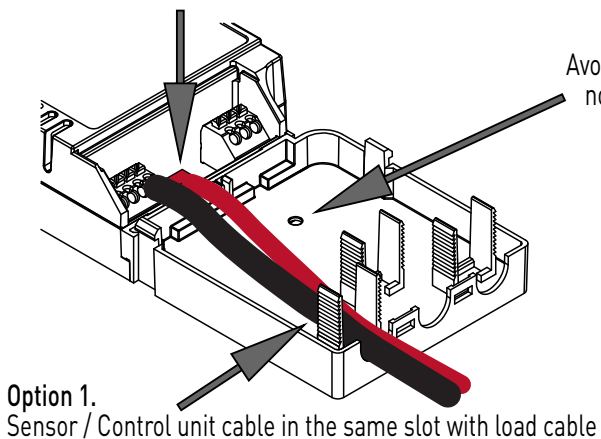

Option 1.
Sensor / Control unit cable in the same slot with load cable

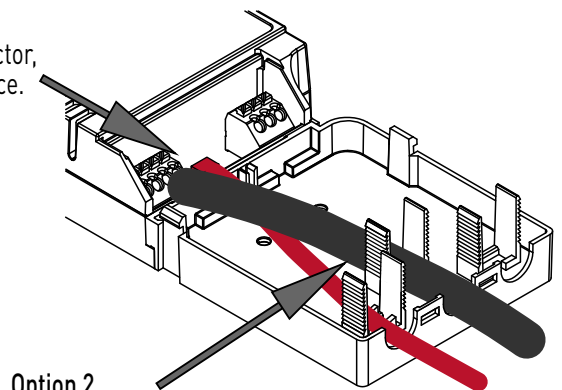

Option 2.
Load cable separately in the center slot
(if load cable diameter > 4,8 mm)

Continues on the next page 

LC-SRA Strain Relief Installation Guide

freedom in lighting

3. Lock wires with the cable clamps.

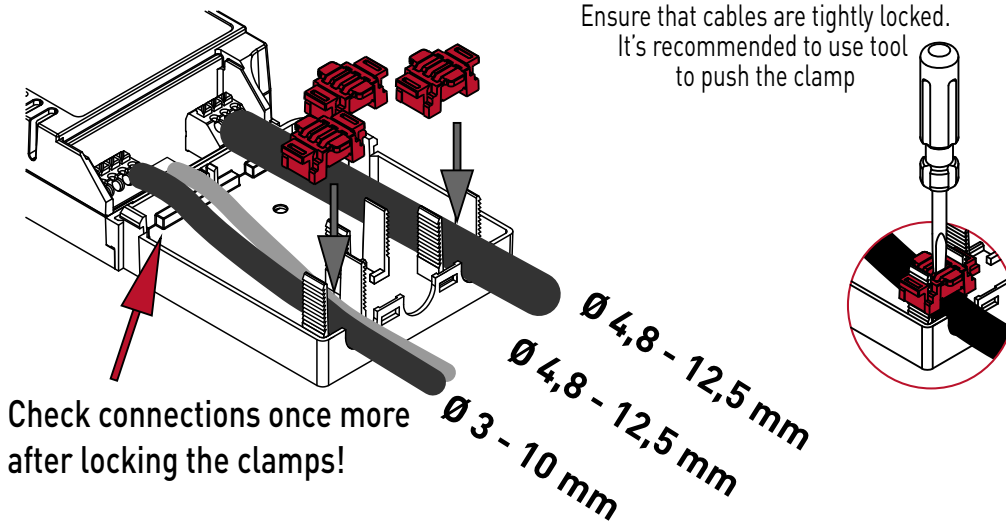

4. Lock the cover on the bottom part.

