

LL1x30-CV12

1x30 W Constant Voltage LED driver

- Maximum 30 W load
- Very low flicker output complying with IEEE 1789 recommendations
- Open & short circuit protection
- Over voltage protection
- 12 V Constant voltage output
- Suitable for use in Class I and Class II luminaires, as well as for independent use
- Double insulated enclosure
- Suitable for use with LL1-CV-DA driver extension for DALI dimmable solutions and LL1-CV-SC for Switch-Control applications

30 W 220-240 VAC 50-60 Hz



Connections

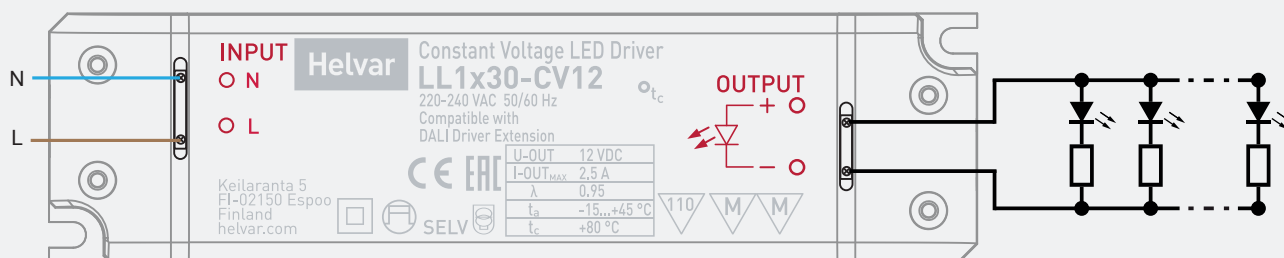

Mains Characteristics

Voltage range	198-264 VAC,
Max mains current at full load	0.2 A
Frequency	50 - 60 Hz
Power factor	0.95
Input Power at no load	0.5 W

Load Output (SELV < 60)

Output voltage (U-OUT)	12 V
Ripple	< ± 3%* at ≤ 120 Hz
PstLM	< 0.04*
SVM	< 0.01*

*] At full power

Max output current (I-OUT)	2.5 A
Max output power	30 W
Efficiency, at full load, typical	0.83

Operating Conditions and Characteristics

Max. temperature at t _c point	80 °C
Ambient temperature range	-15...+45 °C
Storage temperature range	-40...+80 °C
Maximum relative humidity	No condensation
Mains switching cycles	> 100 000 cycles
Life time	30 000h, at TC max (90 % survival rate)

Connections and Mechanical Data

Wire size	0.5 – 1.5 mm ²
Wire type	solid core and fine-stranded
Maximum driver to LED wire length	5m
Weight	240 g
IP rating	IP20

Conformity

Radio Frequency Interference Immunity standard	EN 55015 EN 61547
General and safety requirements	EN 61347-1
Particular safety requirements for d.c. or a.c. supplied electronic controlgear for LED modules	EN 61347-2-13
Performance requirements	EN 62384
Mains current harmonics	EN 61000-3-2
Limits for Voltage Fluctuations and Flicker	EN 61000-3-3
Recommended Practices for Modulating	IEEE 1789- 2015
Current in High-Brightness LEDs for Mitigating	
Health Risks to Viewers	

ENEC, CE, UKCA and SELV marked

Note: See page 2 for dimensions

Dimensions

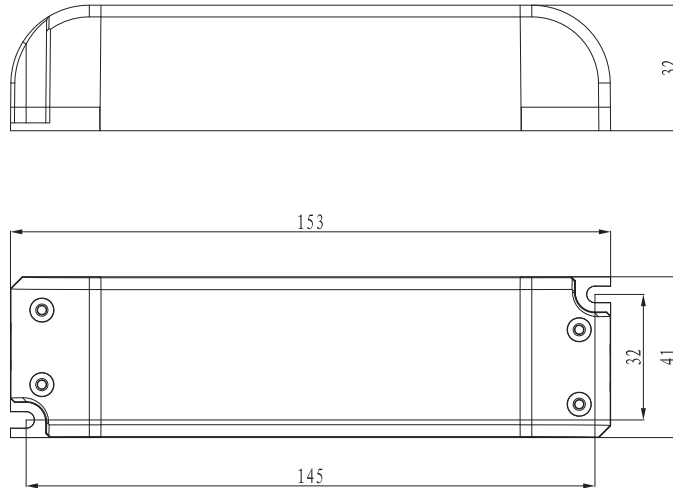

Wiring & connectivity

LL1x30-CV12 LED driver is suited for either in-built and independent luminaire usage. In order to have safe and reliable LED driver operation, the LED luminaires will need to comply with the relevant standards and regulations (e.g. IEC/EN 60598-1). The LED luminaire shall be designed to adequately protect the LED driver from dust, moisture and pollution. The luminaire manufacturer is responsible for the correct choice and installation of the LED drivers according to the application and product datasheets. Specifications of the LED drivers may never exceed the operating conditions as per the product datasheets.

Wiring considerations

Wire type and cross section

- Please refer to datasheets connections & mechanical data

Wiring insulation

- According to recommendations in EN 60598

Maximum wire lengths

- Please refer to datasheets connections & mechanical data

Wire connections

- Please refer to datasheets connections diagram

Miniature Circuit Breakers (MCB)

- Type-C MCB's with trip characteristics in according to EN 60898 are recommended.

Installation & operational considerations

Maximum tc temperature

- Reliable operation and lifetime is only guaranteed if the maximum tc point temperature is not exceeded under the conditions of use.

Installation site

- Ensure that the LED driver does not exceed temperature higher than specified on the product datasheets.
- The general preferred installation position of LED drivers is to have the top cover facing upwards.

Quantity of drivers per miniature circuit breaker 16 A Type C

Based on I_{cont} (pcs.)	Based on I_{peak} (pcs.)	Typ.inrush current I_{peak} (A)	1/2 value time Δt (μs)	Calculated energy $I_{peak}^2 \Delta t$ ($A^2 s$)
68	72	19	182.0	0.0447