

42 W **Constant current** mains track adapter for LEDs

Product code: 5947xxx
(see last page)

42 W 220-240 V 50 – 60 Hz

- In-track adapter with integrated LED driver for luminaires designed for mains voltage track systems
- DIP switch setting for the output current for simple adjustment
- Low current ripple, complying with IEEE 1789 recommendations
- Available in white, black and grey enclosures
- Optional accessory nipple available for mounting the luminaire part

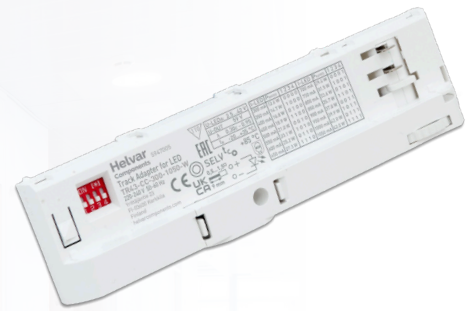

Functional Description

- Adjustable constant current output: 300 mA to 1050 mA (default)
- Output current adjustable through DIP switches
- Suitable for e.g. flicker-free camera recording applications
- Open circuit, short circuit, overload and overvoltage protection
- See the compatibility chart for different track systems on last page

Mains Characteristics

Nominal rated voltage range	220 V – 240 V, 50 – 60 Hz
AC voltage range	198 VAC – 264 VAC
Mains current at full load	Max. 0.27 A
Frequency	50 Hz – 60 Hz
THD at full power	< 10 %
Tested surge protection	1 kV L-N (IEC 61000-4-5) 2 kV L/N-GND (IEC 61000-4-5)
Tested fast transient protection	2 kV (IEC 61000-4-4)

Insulation between circuits & driver case

Mains circuit - SELV circuit	Double/reinforced insulation
Mains and output - Driver case	Double/reinforced insulation

Load Output (SELV <60 V)

Output current (I_{out})	300 mA – 1050 mA (default)
Accuracy	$\pm 5\%$ *
Ripple	< 3 %** at ≤ 120 Hz
	*) Accuracy $\pm 7\%$ when current output < 400 mA
	***) Low frequency
PstLM	< 0.05*
SVM	< 0.01*
	*) At full power, measured with Cree XP-G LED modules.
U_{out} (max) (abnormal)	59 V

I_{LED}	300 mA	350 mA	500 mA	700 mA	1000 mA	1050 mA
P_{Rated}	12.6 W	14.7 W	21 W	29.4 W	42 W	42 W
U_{LED}	2.5 - 42 V	2.5 - 42 V	2.5 - 42 V	2.5 - 42 V	2.5 - 42 V	2.5 - 40 V
PF (λ) at full load	0.89	0.91	0.94	0.95	0.95	0.95
Efficiency (η) at full load	83 %	84 %	85 %	87 %	88 %	88 %

Operating window and driver performance

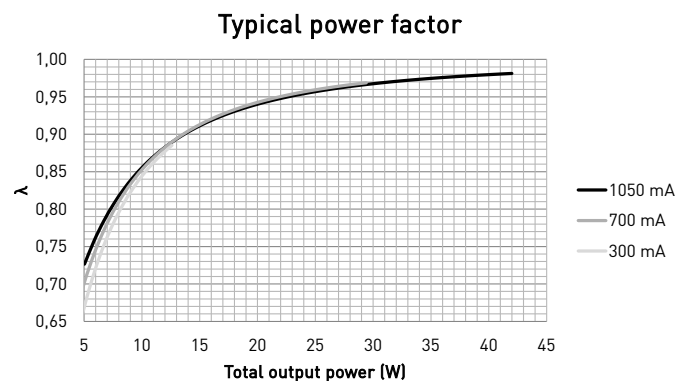
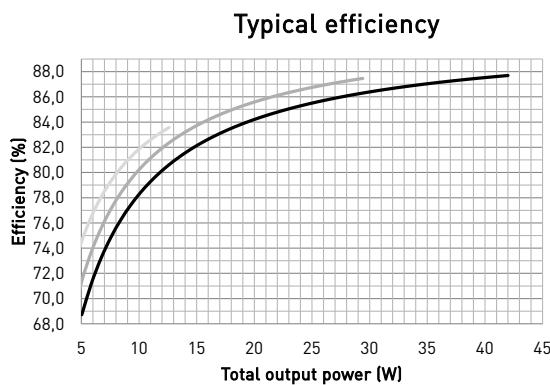
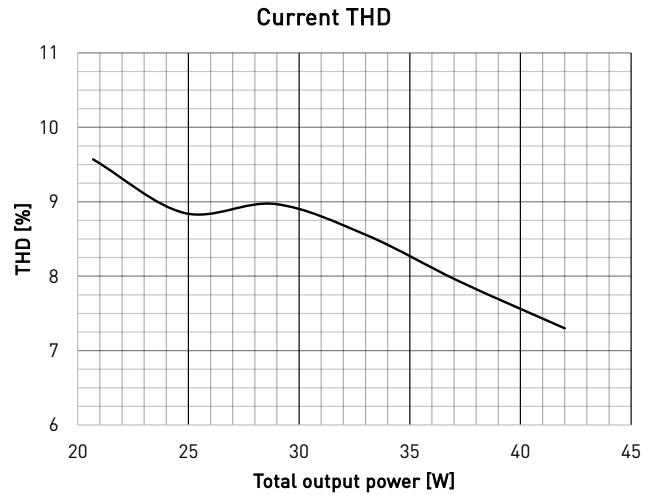
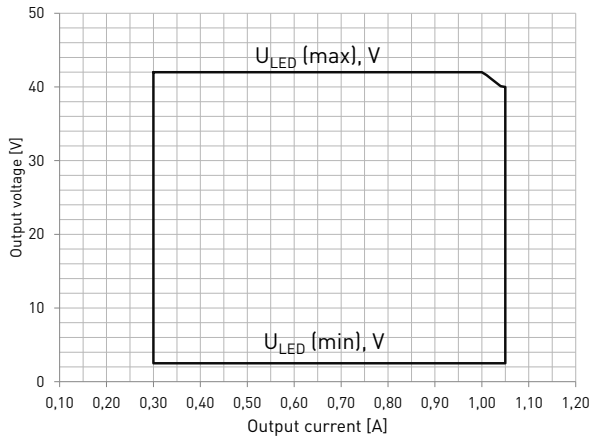

Operating Conditions and Characteristics

Absolute highest allowed t_c point temperature	85 °C
T_c life (50 000 h) temperature	80 °C
Ambient temperature range	-20 °C ... +35 °C*
Storage temperature range	-40 °C ... +85 °C
Maximum relative humidity	No condensation
Mains switching cycles	> 100 000 cycles
Life time (90 % survival rate)	50 000 h, at $t_c = 80$ °C 30 000 h, at $t_c = 85$ °C

*) For other than independent use, higher t_c of the controlgear possible as long as highest allowed t_c point temperature is not exceeded

Quantity of drivers per miniature circuit breaker 16 A Type C

Based on inrush current I_{peak}	Typ. peak inrush current I_{peak}	1/2 value time, Δt
47 pcs.	5.6 A	34 μs

CONVERSION TABLE FOR OTHER TYPES OF MINIATURE CIRCUIT BREAKER

MCB type	Relative quantity of LED drivers
B 10 A	37 %
B 16 A	60 %
B 20 A	75 %
C 10 A	62 %
C 16 A	100 % (see table above)
C 20 A	125 %

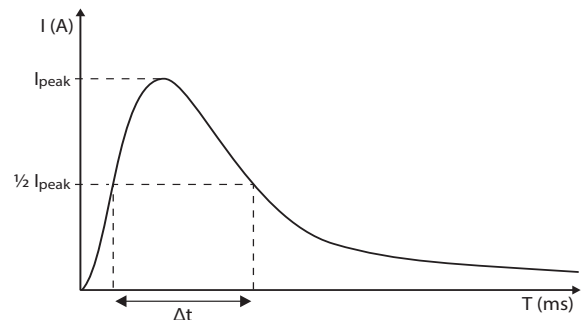

CONTINUOUS CURRENT

Total continuous current of the drivers and installation environment must always be considered and taken into calculations when installing drivers behind miniature circuit breaker. Example calculation of total drivers amount limited by continuous current: $n(I_{cont}) = (16 A (I_{nom, Ta}) / \text{"nominal mains current with full load"}) \times 0.76$. This calculation is an example according to recommended precautions due to multiple adjacent circuit breakers (> 9 MCBs) and installation environment (T_a 30 degrees); variables may vary according to the use case. Both inrush current and continuous current calculations are based on ABB S200 series circuit breakers. More specific information in ABB series S200 circuit breaker documentation.

NOTE! Type C MCB's are strongly recommended to use with LED lighting. Please see more details in "MCB information" document in each driver product page in "downloads & links" section.

Connections and Mechanical Data

Wire size	0.5...1.5 mm ²
Wire type	Solid core and fine-stranded
Wire insulation	According to EN 60598
Maximum driver to LED wire length	20 cm
Weight of the track adapter	116 g
Max withstand weight for luminaire part	5 kg
IP rating	IP20

Connections

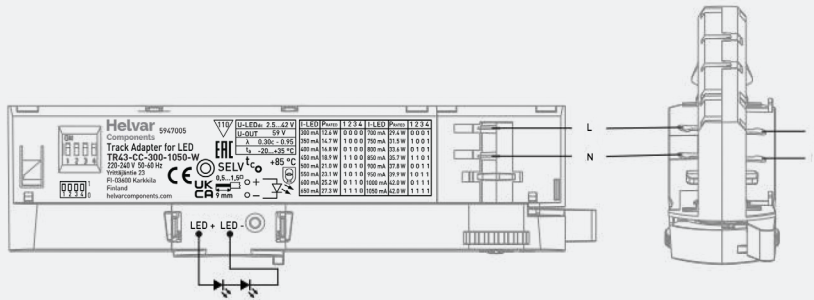

Note:

- Not suitable for load side switching operation

Dimensions

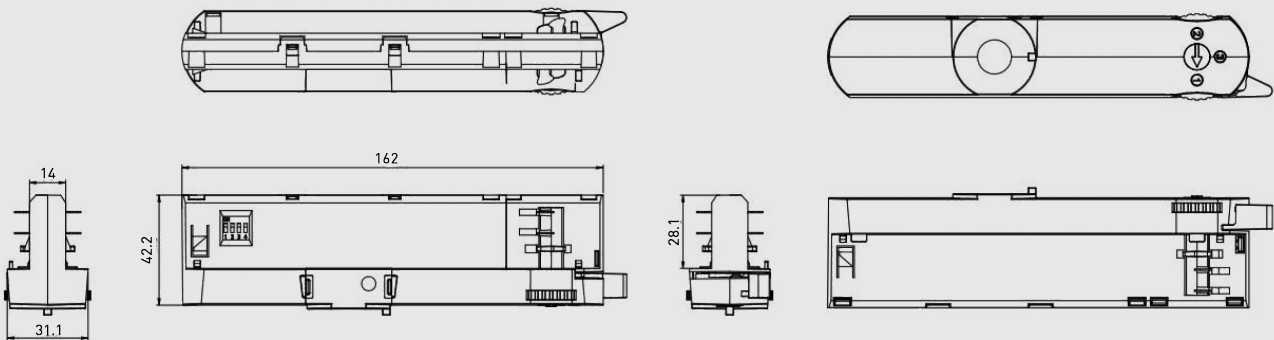

In TR43-CC-300-1050, the current can be set with DIP switches. With each combination of switch setup, a different output current value can be set. The maximum value can be reached with all switches set to "1" (pushed towards the top of the adapter, see connections picture above) and minimum with all switches set to "0". The output current values according to the DIP switch settings are presented below.

DIP switch combinations, output currents and voltage ranges

Dip Switch combination	0000	1000	0100	1100	0010	1010	0110	1110
I _{out} (mA)	300	350	400	450	500	550	600	650
Voltage range	2.5 - 42 V	2.5 - 42 V	2.5 - 42 V	2.5 - 42 V	2.5 - 42 V	2.5 - 42 V	2.5 - 42 V	2.5 - 42 V
Dip Switch combination	0001	1001	0101	1101	0011	1011	0111	1111
I _{out} (mA)	700	750	800	850	900	950	1000	1050
Voltage range	2.5 - 42 V	2.5 - 42 V	2.5 - 42 V	2.5 - 42 V	2.5 - 42 V	2.5 - 42 V	2.5 - 42 V	2.5 - 40 V

TR43-CC-300-1050 LED driver is suited for usage in mains voltage track systems and luminaires. In order to have safe and reliable LED driver operation, the LED luminaires will need to comply with the relevant standards and regulations (e.g. IEC/EN 60598-1). The LED luminaire shall be designed to adequately protect the LED driver from dust, moisture and pollution. The luminaire manufacturer is responsible for the correct choice and installation of the LED drivers according to the application and product datasheets. Operating conditions of the LED drivers may never exceed the specifications as per the product datasheet.

Installation & operation

Maximum ambient and t_c temperature:

- For built-in components inside luminaires, the t_a ambient temperature range is a guideline given for the optimum operating environment. However, integrator must always ensure proper thermal management (i.e. mounting base of the driver, air flow etc.) so that the t_c point temperature does not exceed the t_c maximum limit in any circumstance.
- Reliable operation and lifetime is only guaranteed if the maximum t_c point temperature is not exceeded under the conditions of use.

Miniature Circuit Breakers (MCB)

- Type-C MCB's with trip characteristics in according to EN 60898 are recommended.
- Please see more details in "MCB information" document in each driver product page in "downloads & links" section.

Functionality in abnormal conditions

No load

Output voltage will raise to maximum and return to normal level when load is reconnected.

Short circuit

The driver can withstand short circuit at output side and continue normal operation once the connection fault has been resolved.

Overload

The driver can withstand temporary overload situation and continue normal operation once the load has been corrected.

Conformity & standards

General and safety requirements	EN 61347-1
Particular safety requirements for DC or AC supplied electronic control gear for LED modules	EN 61347-2-13
Thermal protection class	EN 61347, C5e
Mains current harmonics	EN IEC 61000-3-2
Limits for voltage fluctuations and flicker	EN 61000-3-3
Radio frequency interference	EN IEC 55015
Immunity standard	EN 61547
Performance requirements	EN IEC 62384
Recommended Practices for Modulating Current in High-Brightness LEDs for Mitigating Health Risks to Viewers	IEEE 1789-2015
Compliant with relevant EU directives	
RoHS/REACH compliant	
CE / UKCA marked	

Label symbols



Safety isolating control gear with short circuit protection (SELV control gear).



Double insulated control gear suitable for built-in use.



Thermally controlled control gear, incorporating means of protection against overheating to prevent the case temperature under any conditions of use from exceeding 110 °C.

ORDER CODES FOR DIFFERENT COLOURS

TR43-CC-300-1050 LED driver can be ordered in three different LED driver enclosure colours. Please refer to the order codes in the table below.

	Order code	Product name	Driver enclosure colour	Colour code
<i>TR43-CC-300-1050</i>				
Product order codes	5947005	TR43-CC-300-1050-W	White	RAL 9010
	5947105	TR43-CC-300-1050-B	Black	RAL 9005
	5947205	TR43-CC-300-1050-G	Grey	RAL 7036

ORDER CODE FOR ACCESSORY NIPPLE

Optional accessory nipple is available for mounting the luminaire part, details and order code presented below.

	Order code	Product name	Dimensions	Material
Product order code	9500005	TRACK DRIVER ACCESSORY NIPPLE	M10 x 10 mm	Zinc alloy

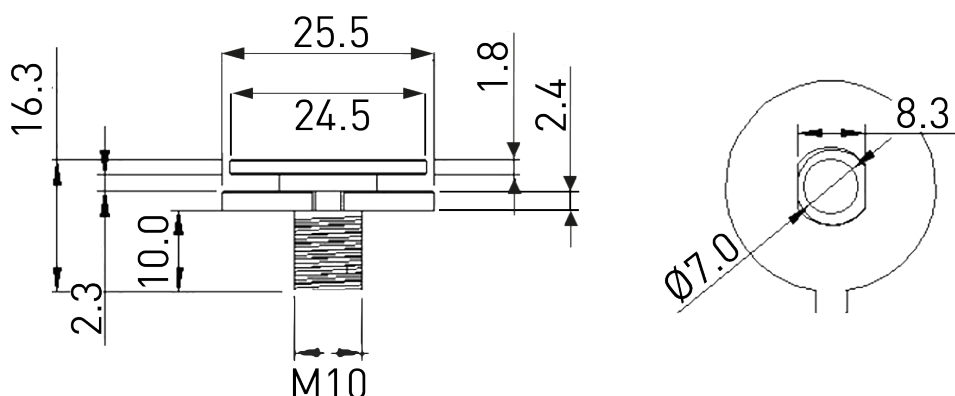

COMPATIBILITY FOR TRACK SYSTEMS

	Manufacturer	Track system type
<i>TR43-CC-300-1050 compatibility</i>		
Track system	Nordic Aluminium	GLOBAL Trac Pro XTS 4 & XTSF 4
	A.A.G. Stucchi	One Track 9000XX Series
	Eutrac	25-XX
	Unipro	T32B
	Ivela	7501

Note: The list is not exhaustive, but includes the track system variants tested for compatibility. Helvar Components can't take responsibility on any possible changes made by different track system manufactures that could affect the compatibility between 3rd party track systems and Helvar Components adapters for LEDs.