

## 28 W 1-10 V dimmable LED driver

- Selectable constant current output: 350 / 500 / 700 mA
- 1-10 V control, 1-100 % dimming range
- SELV output protection for flexibility in luminaire design
- Overload, open and short circuit protection
- External NTC thermal protection input
- Optional strain relief for independent use (LC1x30-SR)
- Long lifetime, up to 100 000 h

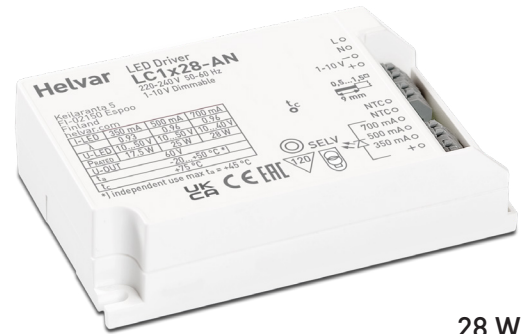

**28 W**  
**220 VAC – 240 VAC**  
**50 Hz – 60 Hz**



### Connections

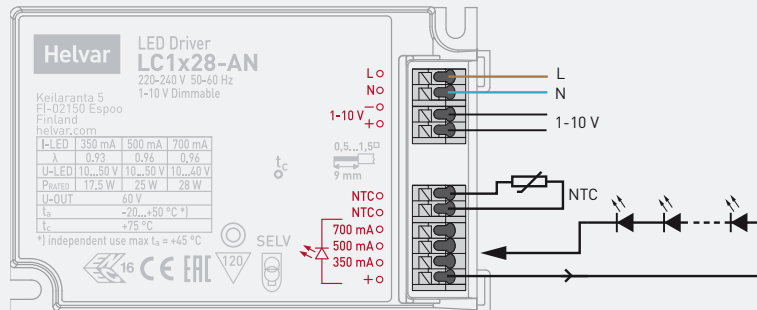

Note:

- Not suitable for load side switching operation.

### Mains Characteristics

Voltage range	198 VAC – 264 VAC
Max mains current at full load	0.10 A – 0.14 A
Frequency	50 Hz – 60 Hz
THD at full power	< 18%
Tested surge protection	1 kV L-N, 2 kV L-GND (IEC 61000-4-5)
Tested fast transient protection	2 kV (IEC 61000-4-4)

### Load Output (SELV < 60 V)

Output current ( $I_{out}$ )	350 mA / 500 mA / 700 mA
- Accuracy	± 5 %
- Ripple	< 2* % at ≤ 120 Hz
PstLM	< 0.02
SVM	< 0.01*

\*] Low frequency, LED load: Cree XP-G LEDs  
 \*) At full load measured with Cree XP-G LED modules.

$U_{out}$ (max) (abnormal)	60 V
Outrush current	800mA at startup/switch off

	350 mA	500 mA	700 mA
$I_{out}$	350 mA	500 mA	700 mA
$P_{out}$ (max)	17.5 W	25.0 W	28.0 W
$U_{out}$	10 V – 50 V	10 V – 50 V	10 V – 40 V
$\lambda_{full\ power}$	0.93	0.96	0.96
Efficiency ( $\eta$ ), full power	0.85	0.86	0.85

### Insulation between circuits:

Mains circuit – control circuit (1-10V): Basic insulation  
 Control circuit (1-10V) – SELV circuit: Supplementary insulation  
 Mains circuit – SELV circuit: Double/reinforced insulation

### Operating Conditions and Characteristics

Ambient temperature range	-20 °C ... +50 °C
in independent use	-20 °C ... +45 °C
Storage temperature range	-40 °C ... +80 °C
Maximum relative humidity	No condensation
Highest allowable $t_c$ point temperature	+75 °C
Life time	50 000 h at $t_c = +75$ °C 70 000 h at $t_c = +70$ °C 100 000 h at $t_c = +65$ °C (90 % survival rate)

### Connections and Mechanical Data

Wire size	0.5 mm <sup>2</sup> – 1.5 mm <sup>2</sup>
Wire type	Solid core and fine-stranded
Wire insulation	According to EN 60598
Maximum driver to LED wire length	5 m
Weight	121 g
IP rating	IP20

Note: See page 2 - 3 for dimensions and additional information

Load output

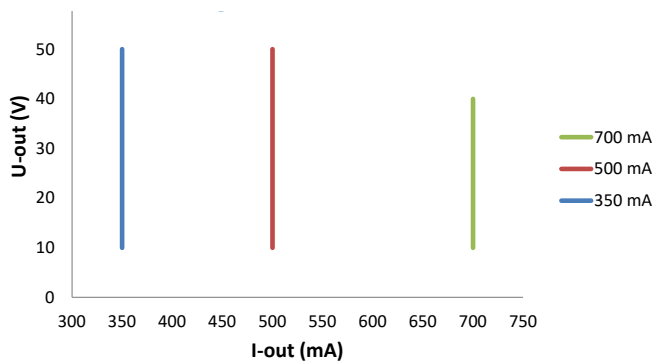

Typical efficiency

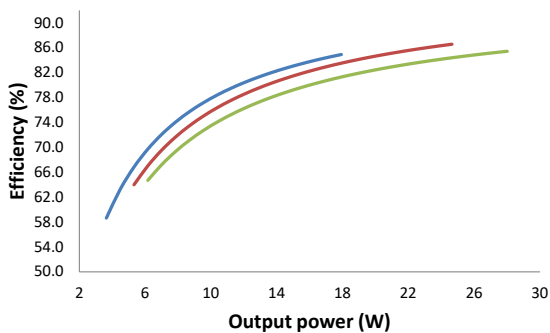

Typical power factor

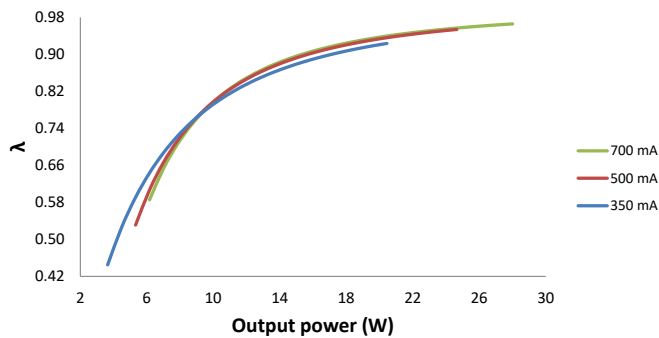

Dimensions

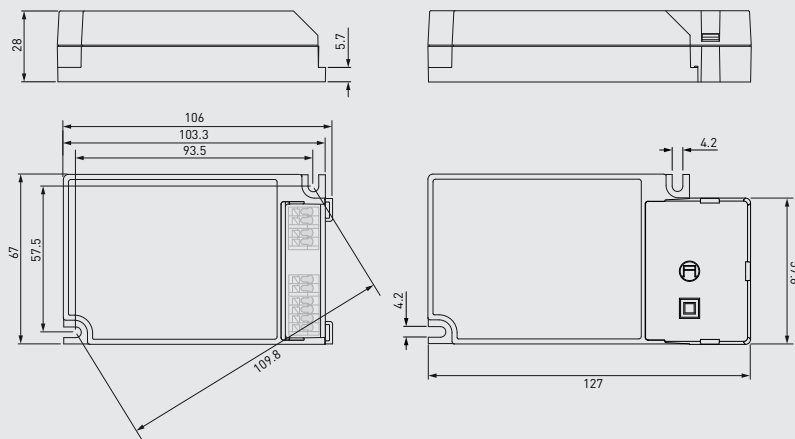

Quantity of drivers per miniature circuit breaker 16 A Type C

Based on $I_{cont}$	Based on $I_{peak}$	Typ.inrush current	1/2 value time, $\Delta t$	Calculated energy, $I_{peak}^2 \Delta t$
75 pcs.	1512 pcs.	7 A	26 $\mu s$	0.0011 A <sup>2</sup> s

Type-C MCB's with trip characteristics in according to EN 60898 are recommended.

LC1x28-AN LED driver is suited for built-in luminaire usage. In order to have safe and reliable LED driver operation, the LED luminaires will need to comply with the relevant standards and regulations (e.g. IEC/EN 60598-1). The LED luminaire shall be designed to adequately protect the LED driver from dust, moisture and pollution. The luminaire manufacturer is responsible for the correct choice and installation of the LED drivers according to the application and product datasheets. Operating conditions of the LED drivers may never exceed the specifications as per the product datasheets.

## Installation & operation

### Maximum Tc temperature

- Reliable operation and lifetime is only guaranteed if the maximum  $t_c$  point temperature is not exceeded under the conditions of use
- Ensure that the  $t_c$  point temperature does not rise higher than specified on the product datasheets

### Installation site

- The general preferred installation position of LED drivers for independent use is to have the top cover facing upwards

## Conformity & standards

General and safety requirements	EN 61347-1
Particular safety requirements for DC or AC supplied electronic control gear for LED modules	EN 61347-2-13
Thermal protection class	EN61347, C5e
Mains current harmonics	EN 61000-3-2
Limits for voltage fluctuations and flicker	EN 61000-3-3
Radio frequency interference	EN 55015
Immunity standard	EN 61547
Performance requirements	EN 62384
1-10 V Control acc. to	EN 60929
Compliant with relevant EU directives	
ENEC and CE / UKCA marked	

Company Address:

**Helvar Oy Ab**

Keilaranta 5

FI-02150, Espoo