

## 1x30 W **Constant Voltage** LED driver

- 24 V Constant voltage output
- Maximum 30 W load
- Very low flicker output complying with IEEE 1789 recommendations
- Driver protection Class II
- Suitable for Class I and Class II luminaires
- Suitable for independent use
- SELV output for driving Class III luminaires
- Suitable for outdoor use (IP67 enclosure)
- Suitable for use with LL1xCV-DA driver extension for DALI dimmable solutions

**30 W 220-240 VAC 50-60 Hz**



### Functional Description

- In-built overvoltage protection, open circuit protection, short circuit protection and overtemperature protection

### Mains Characteristics

Voltage range	198 - 264 VAC
Mains current at full load	Max. 0.4 A
Frequency	50 - 60 Hz
Input Power at no load	0.5 W
THD at full power	< 10%
Tested surge protection	1.2 kV L-N
Typical peak inrush current	16 A*

\* See the MCB chart on page 2 for more details

### Insulation between circuits

Mains circuit - Output (SELV) circuit	Double / reinforced insulation
---------------------------------------	--------------------------------

### Load Output

Output voltage (U-OUT)	24 V
Accuracy	± 5 %
Ripple	< ± 5%* at ≤ 120 Hz
PstLM	< 0.04*
SVM	< 0.01* <span style="float: right;">*) At full power</span>
Max output current (I-OUT)	1.25 A
Max output power	30 W

$V_{out}$	24 V
$P_{out} (max)$	30 W
$I_{out} (max)$	1.25 A
$\lambda$ at full load	> 0.95
Efficiency ( $\eta$ ) at full load	87 %

## Operating window

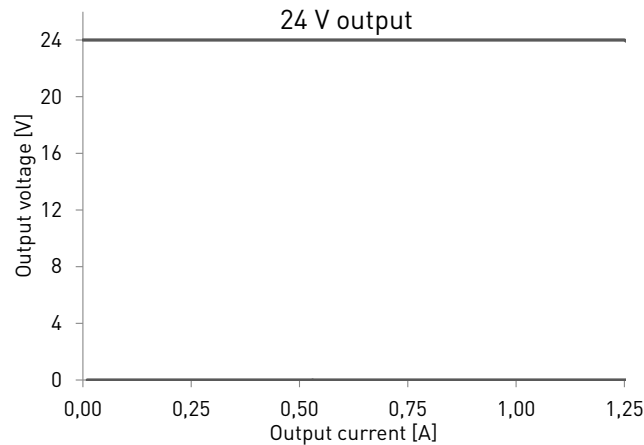

## Driver performance

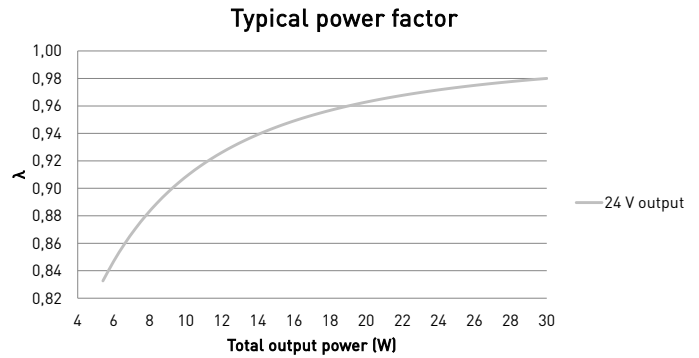
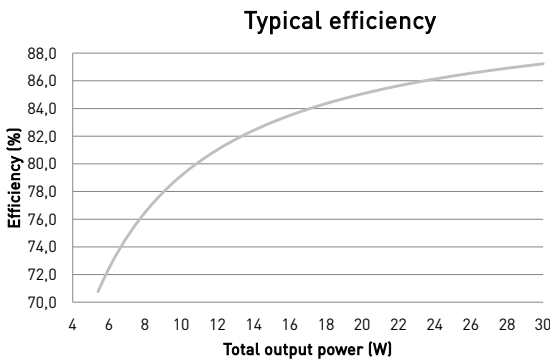

## Operating Conditions and Characteristics

Max. temperature at tc point	80 °C
Ambient temperature range	-15...+45 °C
Storage temperature range	-40...+80 °C
Maximum relative humidity	100 %
Mains switching cycles	> 100 000 cycles
Lifetime (90 % survival rate)	50 000 h, at t <sub>c</sub> = 70 °C 30 000 h, at t <sub>c</sub> = 80 °C

## Quantity of drivers per miniature circuit breaker 16 A Type C

Based on I <sub>cont</sub>	Based on inrush current I <sub>peak</sub>	Typ. peak inrush current I <sub>peak</sub>	1/2 value time, Δt	Calculated energy, I <sub>peak</sub> <sup>2</sup> Δt
72 pcs.	68 pcs.	16 A	208 μs	0.039 A <sup>2</sup> s

## Connections and Mechanical Data

Connection wires	mains wires:	1.00 mm <sup>2</sup> , soldered strips
	load wires:	0.75 mm <sup>2</sup> , soldered strips
Wire insulation		According to EN 60598
Maximum driver to LED wire length		5m
Weight		340 g
IP rating		IP67

## Connections

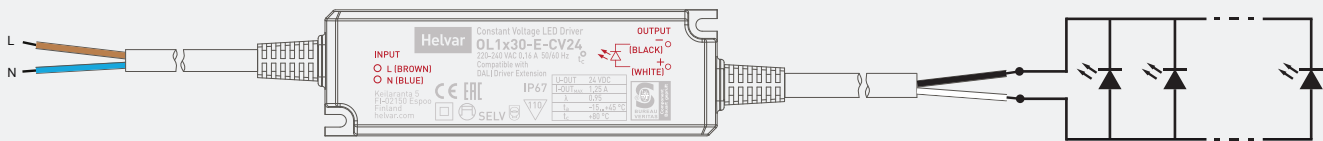

## Dimensions

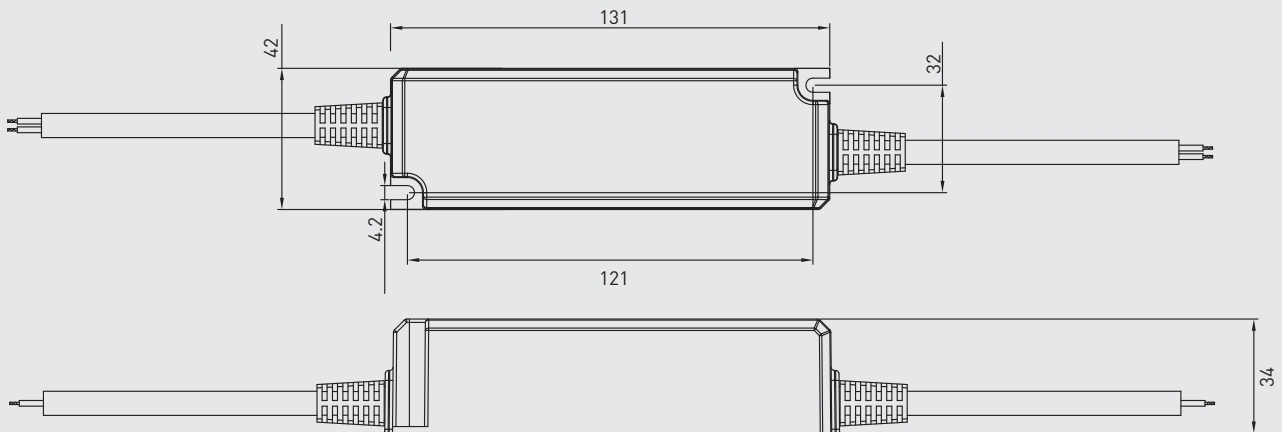

OL1x30-E-CV24 LED driver is suited for inbuilt and independent luminaire usage. In order to have safe and reliable LED driver operation, the LED luminaires will need to comply with the relevant standards and regulations (e.g. IEC/EN 60598-1). The LED luminaire shall be designed to adequately protect the LED driver from dust, moisture and pollution. The luminaire manufacturer is responsible for the correct choice and installation of the LED drivers according to the application and product datasheets. Operating conditions of the LED drivers may never exceed the specifications as per the product datasheet.

## Installation & operation

### Maximum $t_c$ temperature:

- The maximum ambient temperature is a guideline given for luminaire components such as LED drivers. However, integrator must always ensure proper thermal management (i.e. ventilation) so that the  $t_c$  point does not exceed the  $t_c$  max limit.
- Reliable operation and lifetime is only guaranteed if the  $t_c$  point temperature does not exceed the specified maximum  $t_c$  point temperature under the conditions of use

### Installation site:

- The general preferred installation position of LED drivers for independent use is to have the top cover facing upwards
- In order to prevent condensation, relative humidity shall be low enough in relation to the ambient temperature

## Conformity & standards

General and safety requirements	EN 61347-1
Particular safety requirements for DC or AC supplied electronic control gear for LED modules	EN 61347-2-13
Radio frequency interference	EN 55015
Immunity standard	EN 61547
Performance requirements	EN 62384
Recommended Practices for Modulating Current in High-Brightness LEDs for Mitigating Health Risks to Viewers	IEEE 1789-2015
Compliant with relevant EU directives	
RoHS / REACH compliant	
CE / UKCA marked	

## Label symbols



Safety isolating control gear with short circuit protection (SELV control gear).



Double insulated control gear suitable for independent use.



Symbol for independent control gear.



Thermally controlled control gear, incorporating means of protection against overheating to prevent the case temperature under any conditions of use from exceeding 110 °C.